



FEATURES :

- Input/output-base 2500V isolation
- 100% tested at rated current,CE compliant
- Only a potentiometer in need to implement line adjust of output voltage,easy to use.
- Internal varistor(MOV) and RC snubber dual surge absorb protect.
- Thyristor phase control output,adjustable rane widet .
- Thyristor phase control output,adjustable rane widet .

Application :

HGNB series solid state boosters are made up of TRIAC and RC phase control circuit, hysteresis elimation circuit, over voltage snubber, adapting ignition-proof cover, filled with EPOXY, screw thread connection, and have the features of hard structure, vibration-proof capability high, only a potentiometer is needed to implement AC power adjust, used widely instead of cumbersome contacting booster in many fields.

"L" type outputs through SCRs to implement half-wave adjust, mainly used for vibratory feeders.

This series are widely used in the fields of oil apparatus, foodstuff producing mechanisms, packaging and textile machines, manual adjust of power, voltage, temperature, speed etc, analog.

Typical Application:

Industrial temperature controllers

Lighting dimming

Vibratory feeders

Resistive heating element

Conveyor speed Control

Other occasion of power adjust

Unsuitable application:

AC motor control

Three-phase control

Transformers requiring pure sine wave input

Application which cannot withstand thyristor noise

Zero crossing application

PRECAUTIONS :

- RFI will be brought on the output with Thyristor phase control output (The interference will be reduced when seriesing an inductive with the load). .
- Shielding wires or metal tube should be used when the control potentiometer connection line is too long.
- This series products control to load is not isolated:
 1. Potentiometer should be selected with regards to line voltage isolation.
 2. Exercise care to avoid the risk of electric shock .
 3. The control end can not be connected to other electro circuit.
- Heatsink should be used when the current is up to 5 Amperes, and heat-conductive silicate should be spreaded between the heatsink and the base.

- When controlling inductive load, the SSR may be damaged by the high transient voltage and surge current added on the output, so some special clamping devices should be used to control voltage, such as zener diode, varistor (MOV).
- When controlling a small current(close to Min. Load current), a dummy load resistance should be paralleled to reduce the rest higher voltage produced by the leakage current on the output.
- To avoid the temperature exceeding the allowance, heatsink efficiency and the mounting position should be regarded, suitable space will be left when two or more SSR are mounted.
- The output end must not be used in parallel to enlarge the current, nor can it be used in series for higher suitable operating voltage .

SELECTING CODE :

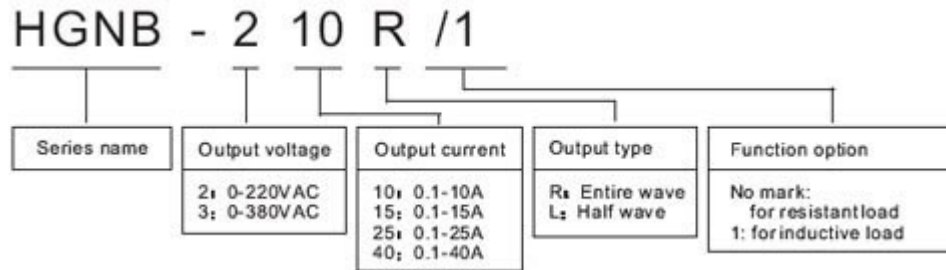

Output parameters (Ta:25°C) :

Output current type	10	15	25	40
Operating voltage range	2:28 280VAC 3:48 480VAC			
Max. Load current	10A	15A	25A	40A
Max. Surge current-Non repetitive (10ms)	120A _{pk}	160A _{pk}	250A _{pk}	300A _{pk}
Max. I t for fusing(10ms)	272A s	128 2As	312 5 sA ₂	450 2As
Thermal resistance junction to case(Rjc)	2.5 °C/W	2.3°C /W	1.1 °C/W	0.9°C /W
Min. Off-state dv/dt	250V/usec	500V/usec	250V/usec	250V/usec
Max. Over-zero voltage	±35VAC			
Min. Load current	100mA			
Max. On-state voltage drop	2.2VAC@rated current			
Max. Off-state leakage current	5mA @rated voltage			
Transient over voltage	2:800Vpk 3:1000Vpk			
Operating frequency range	47 63Hz			
Dielectric strength 50Hz 1Min()	2500VAC input-output 2500VAC input/output-base			
Insulation resistance	1000MQ 500VDC Voltage Test			
Vibration resistance Destructive Functional	117.6mm/s ² (12G),10-55 Hz double Amplitude of 2 mm 117.6mm/s ² (12G),10-55 Hz double Amplitude of 2 mm			
Destructive FunctionalShock resistance	Min.980m/s ² (100G)(5 times each for X,Y,Z axis) Min.980m/s ² (100G)(4 times each for X,Y,Z axis)			
Ambient operating temperature	-30°C to 80°C			

Ambient storage temperature	-30°C to 120 °C
Ambient humidity relative	45% to 85%
Weight typical	≤85g

Dimensions :

CONNECTION/WIRING :

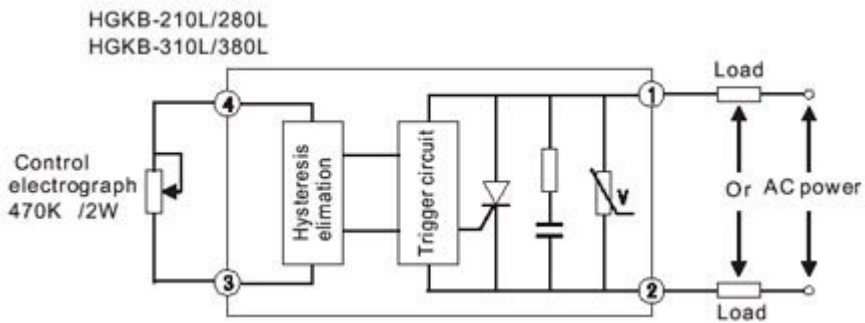
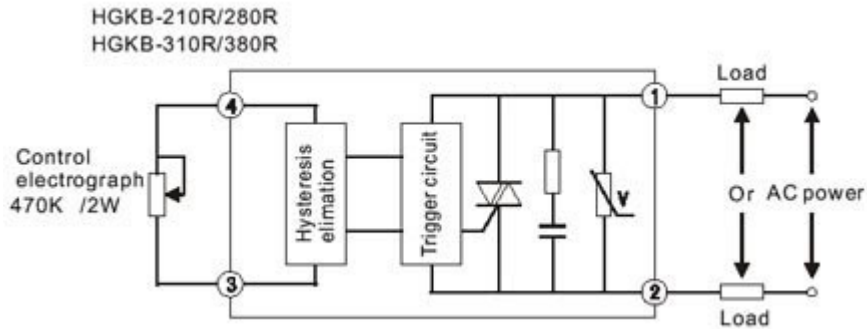

CURRENT DERATING CURVES :

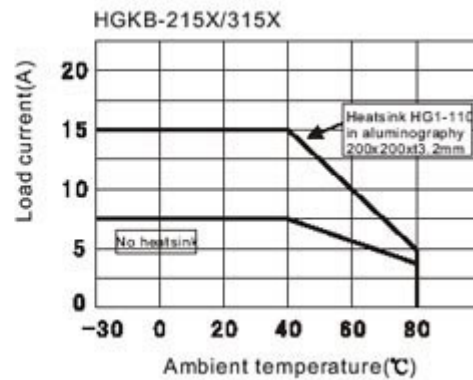
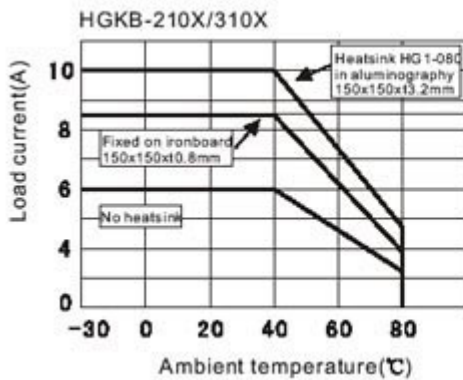

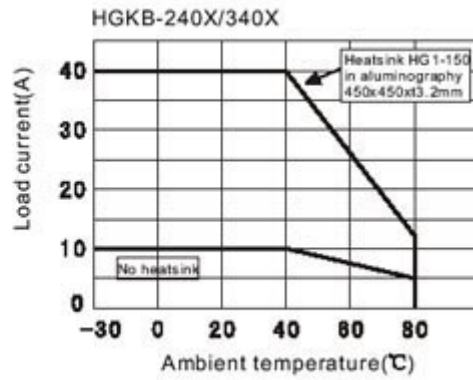
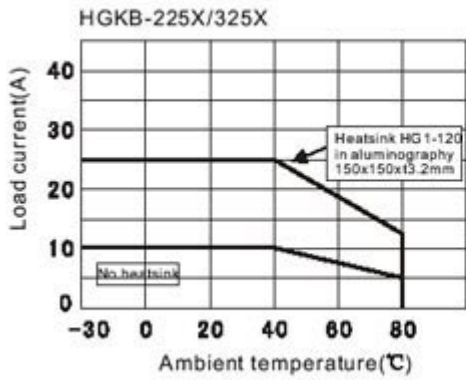

PERCENTAGE ON vs. INPUT RESISTANCE

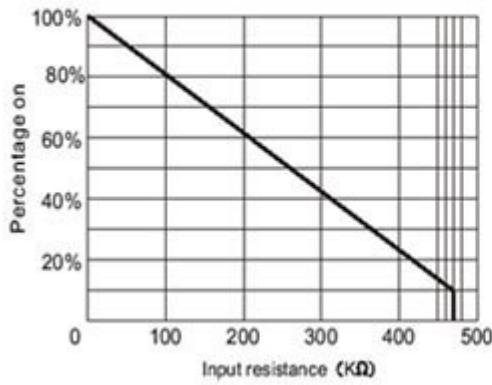

MAX. SURGE vs. DURATION

